



# CEDAR PEAKS<sup>®</sup>

SUPER POLYMER SIDING



# REFINED BEAUTY AND PERFORMANCE

Cedar Peaks® superior design and engineering provides proven dependability and performance. From its Patented Twister Lock and Cyclonic Locking System, Super Polymer Formulation, and low maintenance, .046", .048" & .050" Cedar Peaks, with its sophisticated cedar woodgrain finish, is backed by a **Lifetime Limited Warranty** and is the choice of discriminating renovators and homeowners that want tried-and-true performance and classic architectural elegance.

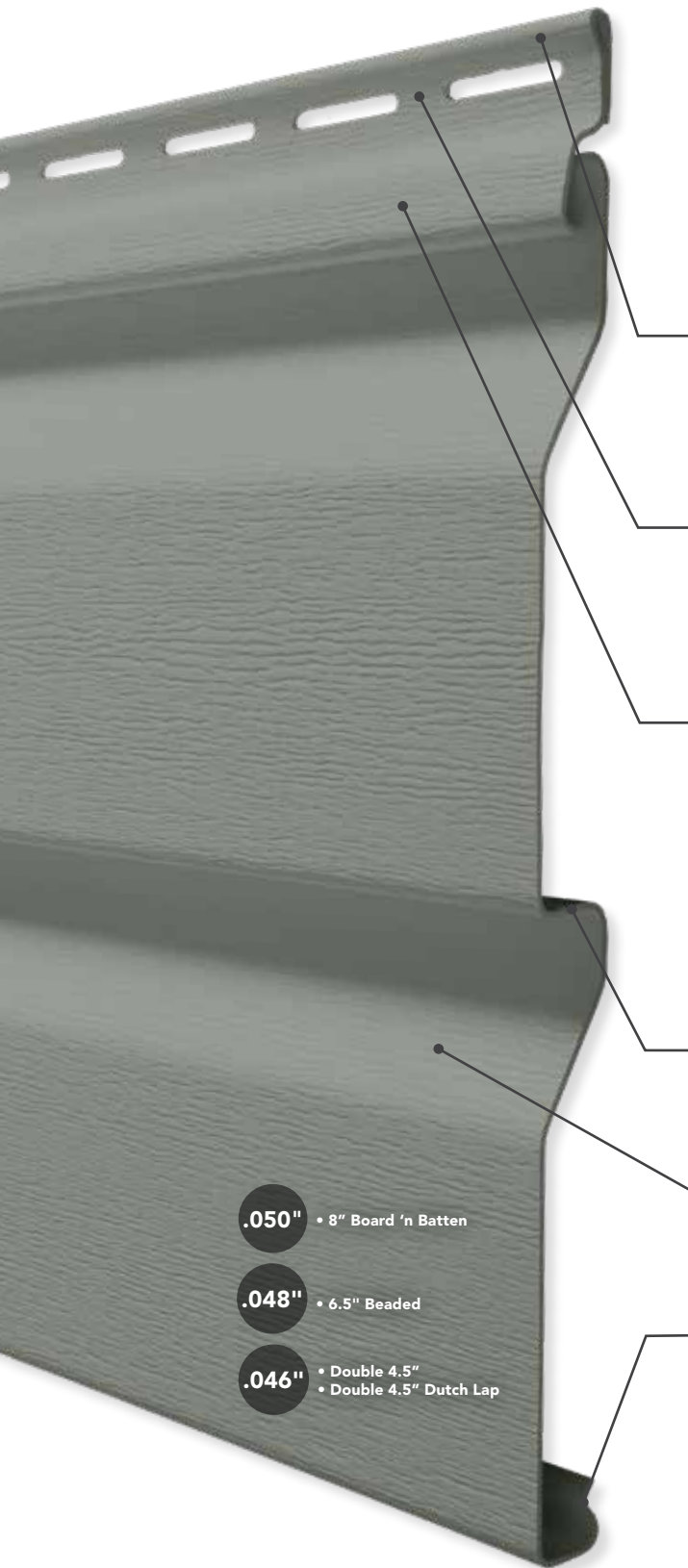

## 1 High-Tension Structural Return & Nail Depth Guide

- Enhances the double-ply nailing hem
- Increased structural stability in high winds
- More rigid connection to the exterior wall
- Helps prevent nails from being nailed too tightly

## 2 Double-Ply Nailing Hem (D4.5 & D4.5DL ONLY)

- Double the tear resistance
- More rigid connection to the exterior wall
- Increased structural stability
- Increased high wind performance

## 3 Patented Twister Lock and Cyclonic Locking System

- Bolsters the lock in winds up to 238 mph
- Increased blow-off resistance
- Enhances overall rigidity of siding system on the wall



**Windload tested to 238 mph  
(201 mph for 6.5" Beaded, 216 mph  
8" Board 'n Batten)**

Windload testing is based upon ASTM 5206 testing and the results are reported per ASTM 3679 section 5.11. Florida Building Code FL#1712.5

## 4 5/8" Panel Projection

- Enhanced shadow lines
- Added panel rigidity

## 5 Tested and Certified

- Meets or exceeds ASTM standards
- Meets or exceeds VSI Product Certification

## 6 Drop Guard

- Prevents the panel from dropping out of the lock during installation
- Secures the patented Twister Lock and Cyclonic Locking System

**.050"** • 8" Board 'n Batten

**.048"** • 6.5" Beaded

**.046"** • Double 4.5"  
• Double 4.5" Dutch Lap

### PANEL THICKNESS



# WHAT'S INSIDE SUPER POLYMER?

ProVia's Super Polymer formulation is comprised of our Tri-Pigment Reflective Technology, Weather Barrier Shield, SPX-2000 UV Protection and Color Keeper Anti-Fade Protection. Inorganic materials, anti-weathering ingredients, butyl and acrylic modifiers are melded together to create a strong molecular chain for superior color retention and weather resistance.

What does this mean to you? This means peace of mind knowing your home is clad in the industry's best vinyl siding.



## Tri-Pigment Reflective Technology

- A concentration of precisely formulated anti-weathering materials at the product surface.
- Helps ensure long-lasting color fidelity and maintenance freedom for your home's exterior.



## Weather Barrier Shield

- A precise formulation of heat resistant inorganic pigments ensuring exacting deep colors.
- Reflects heat away from exterior walls and deflects damaging infrared solar rays to reduce solar heat build-up and unsightly weathering.



## SPX-2000 UV Protection

- Helps block the destructive effects of the sun's UV rays.



## Color Keeper Anti-Fade Protection

- Meticulously engineered with the finest mix of ingredients that build a stronger molecular chain for superior color retention.

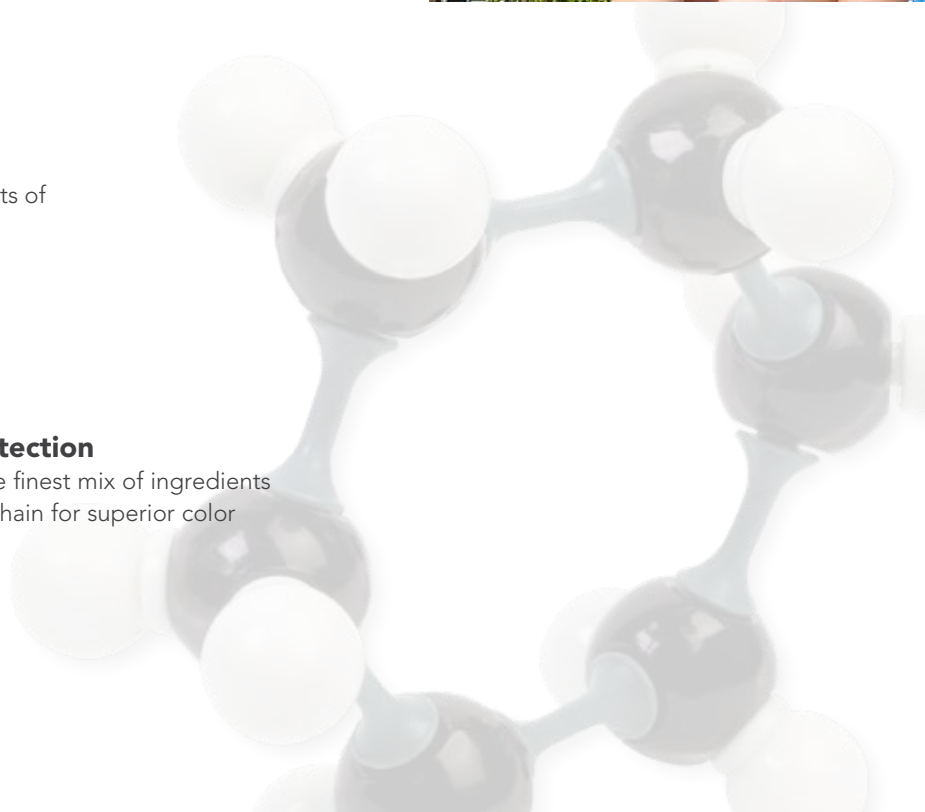

# EXCEPTIONAL PERFORMANCE



## IMPACT RESISTANCE?

Vinyl Siding impact resistance is the ability of the vinyl materials to withstand a high force or shock applied to it over a short period of time. A high force over a short time has a greater effect than a weaker force over a longer period of time. The impact is also proportionate to the relative velocity of the colliding materials.

### How does ProVia's Super Polymer Formulation provide industry-leading Impact Resistance?

Our Super Polymer formulation is engineered with high-grade impact modifiers that act as shock absorbers. These impact modifiers add strength, toughness and durability and provide our siding with the highest impact resistance for the life of the products.

Based on historical warranty analysis, ProVia's siding products had little to no hail damage warranty claims.



### Third Party Accreditation and Testing

ProVia's Super Polymer vinyl siding is ASTM 4226 certified and tested for impact resistance that exceeds 60 lb/ft.

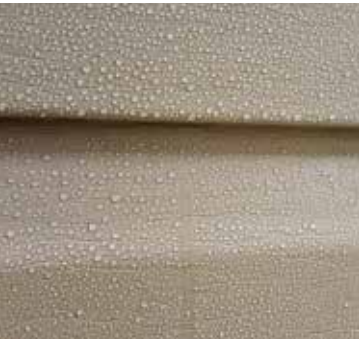

## IMPERVIOUS TO MOISTURE

Unlike wood and fiber cement, ProVia's Super Polymer formulation is engineered with high-grade weathering defenses that enhance the inherent water resistance of vinyl. This ensures moisture management for your home's exterior and provides long-lasting performance for the life of the product.

## INHERENTLY FLAME RETARDANT

Our siding products are Class A fire rated based on ASTM E84, ASTM D635 and ASTM E119-88 testing and certification. ProVia's Super Polymer formulation is a PVC (vinyl) based product which does not ignite quickly and is inherently flame retardant.

Most home structure fires originate in the interior of the home. Only 4% of house fires start on the outside of the structure and fewer than 2% of house fires originate with the exterior wall surface.



*-National Fire Protection Association, Home Structures Fires, April 2013*

## LOW MAINTENANCE?

Homeowners want their home's siding to look great for as long as possible. That's why ProVia has not only engineered its Super Polymer Siding products to perform, but to be low-maintenance.

### Easily cleaned with

- ✓ Mild detergent
- ✓ Brush
- ✓ Garden Hose

### What does this mean?

- ✗ No painting
- ✗ No staining
- ✗ No caulking
- ✗ No sealing
- ✗ No re-pointing of mortar



### Save money by reducing maintenance costs.

Visit [provia.com/siding](http://provia.com/siding) for more information on how to clean vinyl siding.

### Did you know?

Since ProVia's vinyl siding does not require painting, staining, or caulking, no harmful solvents are released into the environment to maintain it. As a result, ProVia's vinyl siding can earn points in leading green building certification programs.

## QUALITY SECOND-TO-NONE



ProVia's vinyl siding products are meticulously engineered to meet or exceed ASTM standards set forth by the Vinyl Siding Institute (VSI). As a result, contractors, installers and homeowners benefit from product durability, longevity and performance for a lifetime.

## PEACE OF MIND

# LIFETIME

LIMITED WARRANTY

Unlike fiber cement, wood or stucco, ProVia's Super Polymer formulation is engineered with high-grade weathering defenses that enhance the inherent water resistance of vinyl. This ensures moisture management for your home's exterior and provides long-lasting performance for the life of the product.



# CEDAR PEAKS® COLORS

## Lifestyle Collection

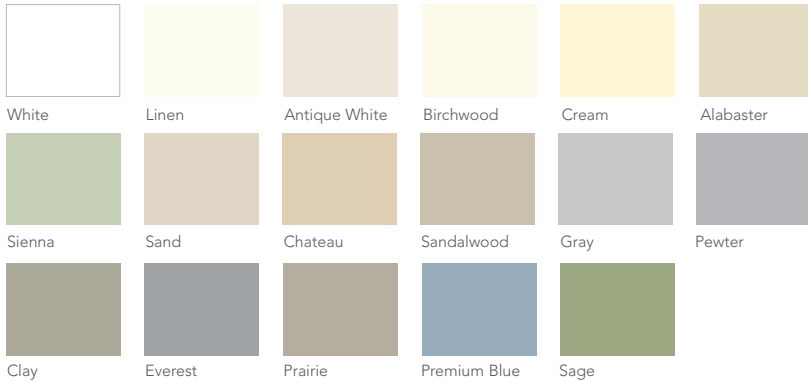

## Signature Collection

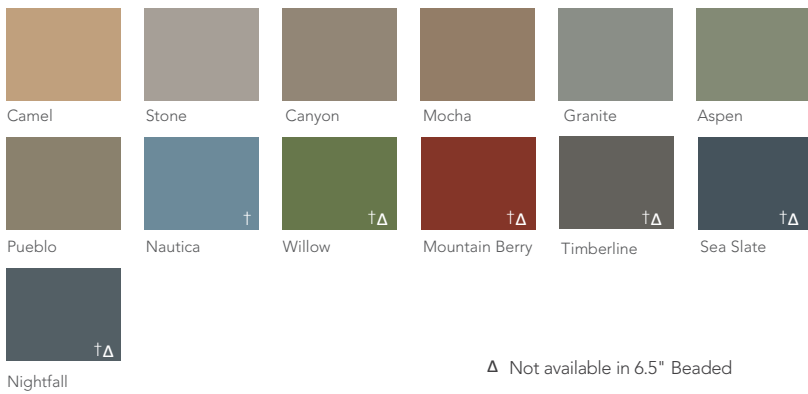

Δ Not available in 6.5" Beaded  
 † Not available in Board 'n Batten



Complete the look of your home's exterior by coordinating Cedar Peaks vinyl siding with ProVia's extensive portfolio of products.

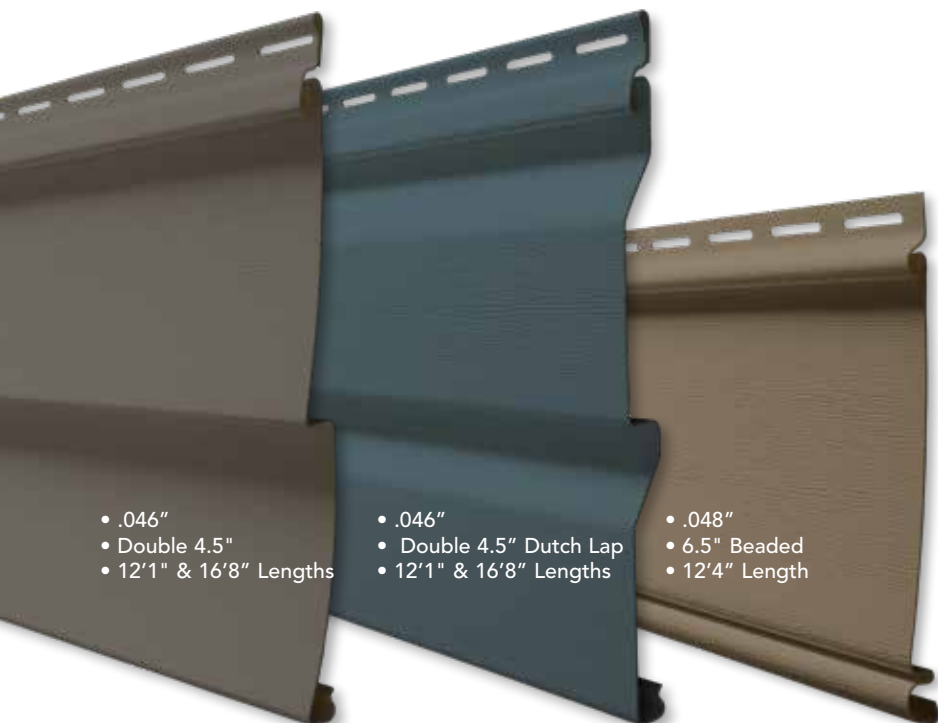

- .046"
- Double 4.5"
- 12'1" & 16'8" Lengths

- .046"
- Double 4.5" Dutch Lap
- 12'1" & 16'8" Lengths

- .048"
- 6.5" Beaded
- 12'4" Length

- .050"
- 8" Board 'n Batten
- 10' Length

Always refer to our color selector for accurate color representation.

# COORDINATING ACCESSORIES



**A - Round Vent**

OR



**A - Octagon Vent**



**B - Board 'n Batten**

OR



**B - Polypropylene Shake**



**C - Vented Soffit**

OR



**C - Solid Soffit**



**D - Trim Coil**



**E - Outside Corner Post**



**F - Inside Corner Post**



**G - Window/Door Surround**



**H - Light Block**



**I - J-Channel**



**J - F-Channel**



**K - Undersill Finish Trim**



**L - Starter Strip**



“To serve, by caring for details in ways others won’t.” It’s not just our mission, but a way of letting our light shine every day at ProVia. We continually strive to put these words into action by providing unmatched quality and service. The heart-shaped weep hole symbolizes each employee’s commitment to devoting the utmost care, pride and quality into each building product we manufacture...it’s The Professional Way.



Doors • Windows • Siding • Stone  
[provia.com](http://provia.com)

© 2019 ProVia  
H-MK-20200-19 • 11/18



Distributed by: